

Pump specification:

Type: RAPTOR 8E
Max. flow: 500 m³/h
Max. pressure: 32 m
Connection size: 8"
Solids handling: 115 mm
Impeller type: screw impeller
Priming system: equipped
Electric motor: 18.5kW (4PoleVoltage 400/690V 50 Hz)
Frame LxBxH: 2500x1100x1600 mm
Dry weight: 1700 kg

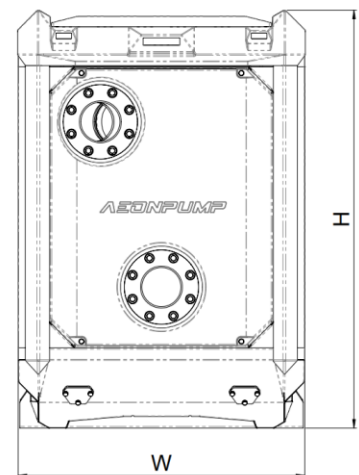
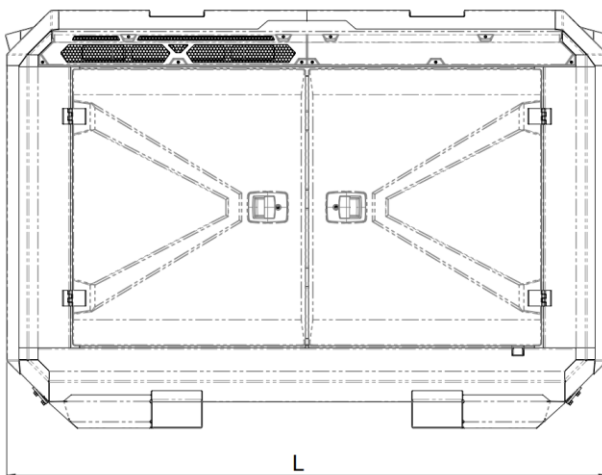

FEATURES AND COMPETITIVE EDGE

- Long maintenance intervals;
- High quality parts and long lifetime;
- Innovation, online telemetry and remote access capability;
- Designed for heavy duty applications in sewage, drainage and dewatering bypass;
- Industry leading efficiency;



PUMP TECHNICAL SPECIFICATION

Pump

Max. flow: 500m³/h
Max. pressure: 32 m
Impeller type: Screw impeller
Solids handling: 115 mm
Temperature: max. 40 °C
Casing: GG25 (0.6025)
Impeller: GGG60 (0.7060)
Suction Liner: GG20 (0.6020)
Suction liner adjustable by external regulation screws.
Wear Ring: GG20 (0.6020)
Shaft: 1.4021
Shaft Sealing: WC/SiC/NBR
O-Rings: NBR
Power kW: 18.5kW
Rated Voltage: 400/690V 50Hz
4-pole: 1470RPM
E3: EC Directive 2005/32

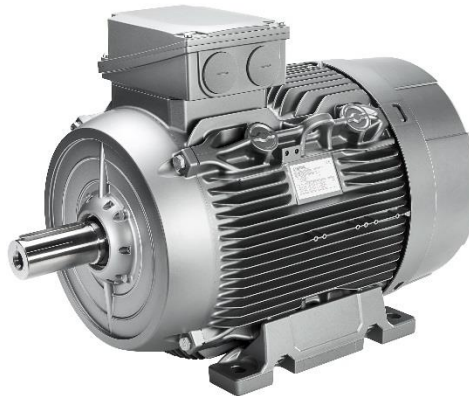
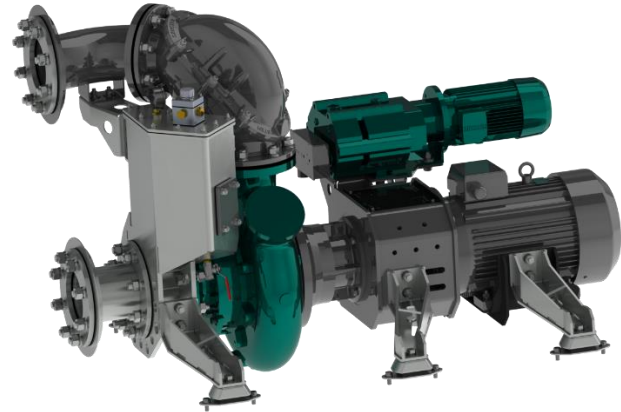

Priming system

Air handling capacity: 60 m³/h
Max. vacuum: 9.0 m
Electric motor: 1.3kW
Floatbox: HDG steel
Non return valve: Ductile iron GJS400
Check valve ball: Rubber NBR
Motor brand: OME
Power kW: 1.3kW
Rated Voltage: 400/690V 50Hz
4-pole: 1470RPM
E3: EC Directive 2005/32

Frame or canopy

Frame or canopy: Stackable
Material: Steel HDG
Dimensions LxWxH: 2500x1100x1600mm
Lifting point: Single lifting point
Forklift pockets: forklift pockets
Control unit: Frequency converter / star/delta switch

Curves at speed 1470rpm

(Testing according ISO 9906:2012-38)

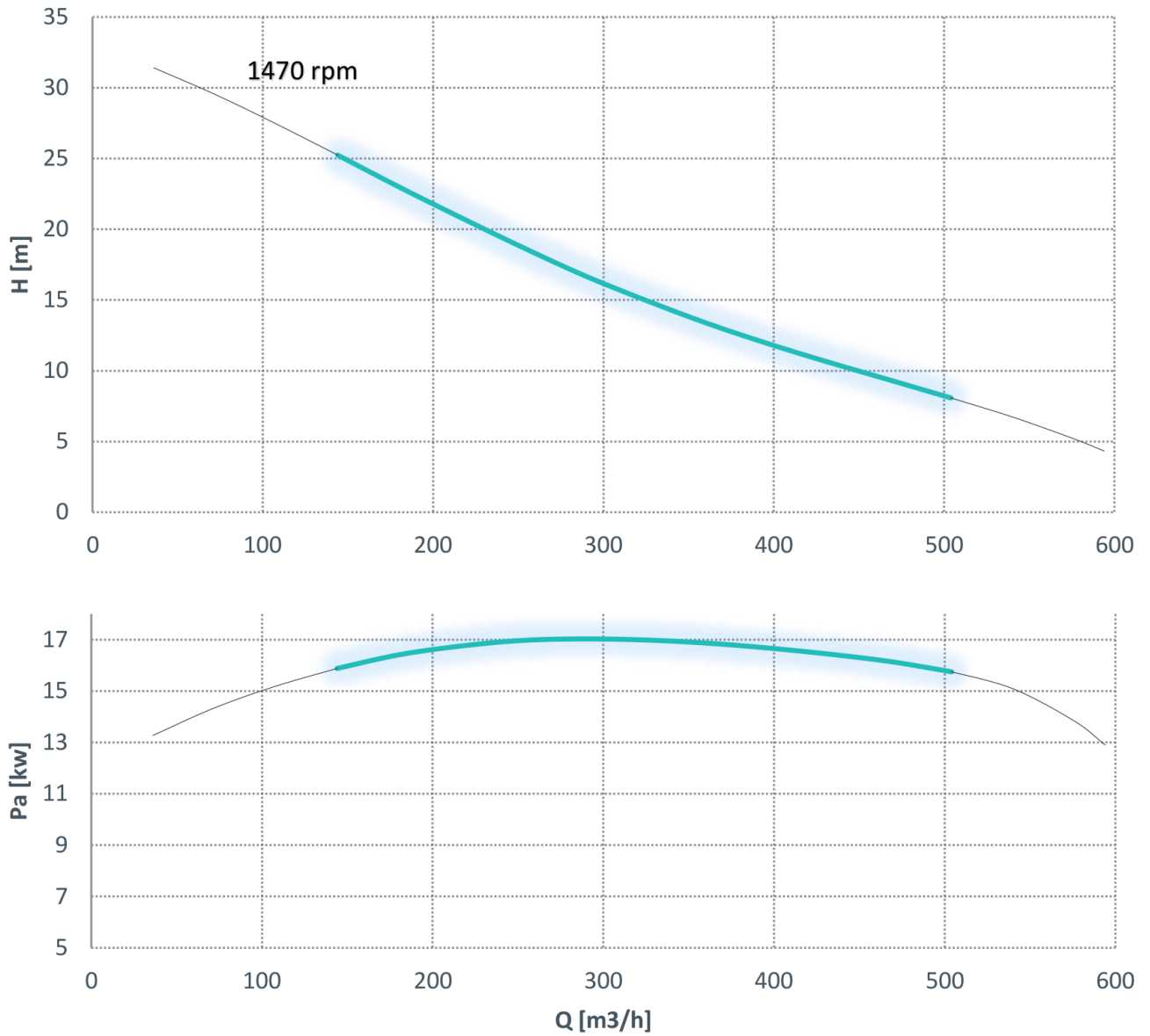

Note: Pump power P include mechanical seal friction and bearing frame losses, from a run in bearing frame.